



CORONADO[®]

A Meade Instruments Company

90mm SolarMax[®] III Series

Hydrogen-Alpha Solar Telescopes

With RichView[™] Tuning





WARNING!



Looking at the Sun can be very dangerous unless the proper precautions are taken and specialized solar viewing equipment, like Coronado Solar filters and telescopes are used. Never look at the Sun directly with your eyes. When using Coronado filters on a telescope not designed specifically for solar viewing, be sure to block all non-filtered optical components such as viewfinders to prevent the sun's light from passing through. An inadvertent glance through an unfiltered or improperly filtered optical system can cause immediate and permanent damage to the eye. Never allow unattended children to operate or be near a solar telescope system.

Coronado SolarMax hydrogen-alpha telescopes and filters are designed and tested to provide safe viewing of the Sun. These systems consist of two critical parts: The etalon filter that may be mounted at the front of the telescope or internally inside the telescope tube and the blocking filter that is mounted at the back of the telescope. Both of these components must be properly installed to provide safe solar viewing. Most Coronado blocking filters (BF filters) are installed in a special diagonal that mounts at the rear of the telescope and holds the eyepiece. Do not replace this diagonal with any other diagonal. Without the blocking filter inside the **dedicated Coronado diagonal**, light from the sun is not fully filtered and looking through the system can result in eye damage even with a quick glance.

READ THIS MANUAL COMPLETELY BEFORE ATTEMPTING TO USE YOUR NEW CORONADO PRODUCT. IT CONTAINS SPECIFIC INSTRUCTIONS REQUIRED FOR THE SAFE USE OF YOUR PRODUCT.

Meade Instruments has night and day covered for the amateur astronomer. Meade is the leader in night time astronomy with the most advanced optical, mechanical and electronic systems for viewing the night sky. With Coronado and the development of the SolarMax, Meade is the clear leader in solar day time observing as well. Whether you are imaging deep sky objects with your Meade astronomical telescope or gazing at our nearest star through a Coronado SolarMax telescope, keep an eye on the Meade team to provide you with the most technologically advanced and innovative product to enhance your enjoyment of astronomy. No matter where, or what time of day your interest in astronomy calls to you, we will be there with you.

Night and Day, we've got you covered.



Table of Contents

About Coronado®	5
Filter Safety	6
SolarMax® III 90 Telescope	7-12
SolarMax® III H-α Filter Sets	13-15
Cleaning	16
Care	16
Additional Support and Accessories	17
Definition of Terms	18
H-α Solar Features	19
Solar Facts	20
Troubleshooting	20-21
Warranty	22-23

About Coronado

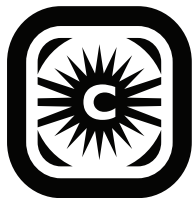

Coronado was founded in 1997 and has been at the forefront of solar astronomy since its beginning. Its innovation in both optical design and construction of the classical Fabry-Perot etalon has allowed solar astronomy to be available to the average consumer. Coronado's patented technology and improved manufacturing techniques has made solar telescopes more affordable and desirable than ever before. Tremendous demand changed the initial concept of producing a few hydrogen-alpha ($H-\alpha$) telescopes a month for the advanced solar amateur.

As word got out that these telescopes and filters produced amazing views of the Sun, Coronado grew rapidly. As demand vastly exceeded the small company's ability to produce, the owners of Coronado decided to sell their operation to a company with the experience in higher volume manufacturing but still had then dedication to quality and detail that Coronado was known for. That company is Meade Instruments.

In June of 2010 Meade Instruments Corp. announced the introduction of the revolutionary SolarMax II line of solar observing telescopes and filters. The new SolarMax II was a breakthrough in solar observing with the new RichView™ tuning system. This patented system allows direct tuning of the primary etalon filter. No other commercially available $H-\alpha$ telescope can provide the tuning range and accuracy of the SolarMax II. Observers can now tune for the highest contrast views of active regions, flares, filaments, and other surface detail, or quickly and easily re-tune for prominences on the solar limb.

We continue to maintain the founders philosophy for building filters — Safety, Quality, and Performance. You can rest assured that your new instrument has been hand assembled and tested before being sealed in the box. In fact, every telescope and filter is field tested on the Sun so we are confident you can look forward to a lifetime of fantastic $H-\alpha$ views of our dynamic Sun. If you have any questions please do not hesitate to contact us.

Filter Safety



Safety - It is widely known that there are inherent dangers involved with observing the Sun. Meade Instruments has always been, is, and always will be, obsessed with the safety of its products. A proposed new product is not released until it has been fully proven that it can be made completely safe for the user. All Coronado instruments are tested and sealed at our facilities as complete, safe, and working units. Do not attempt to disassemble any Coronado product, doing so will void your warranty and could compromise your safety. Before each use make sure your filter does not appear damaged in any way. If you have any doubts please call our customer support. Meade is obsessed with safety and you should be too.

We recommend you establish a safety checklist for each viewing session, ensuring that all adaptors, filters and blocking filters are installed and secure before aligning the system to the sun. Make this safety check part of your observing routine. Never leave a solar telescope unattended.

An additional safety consideration is exposure to the Sun. Always use sunscreen, and wear a hat and long sleeved shirt while observing.

SolarMax[®] III 90 Dedicated H- α Telescope

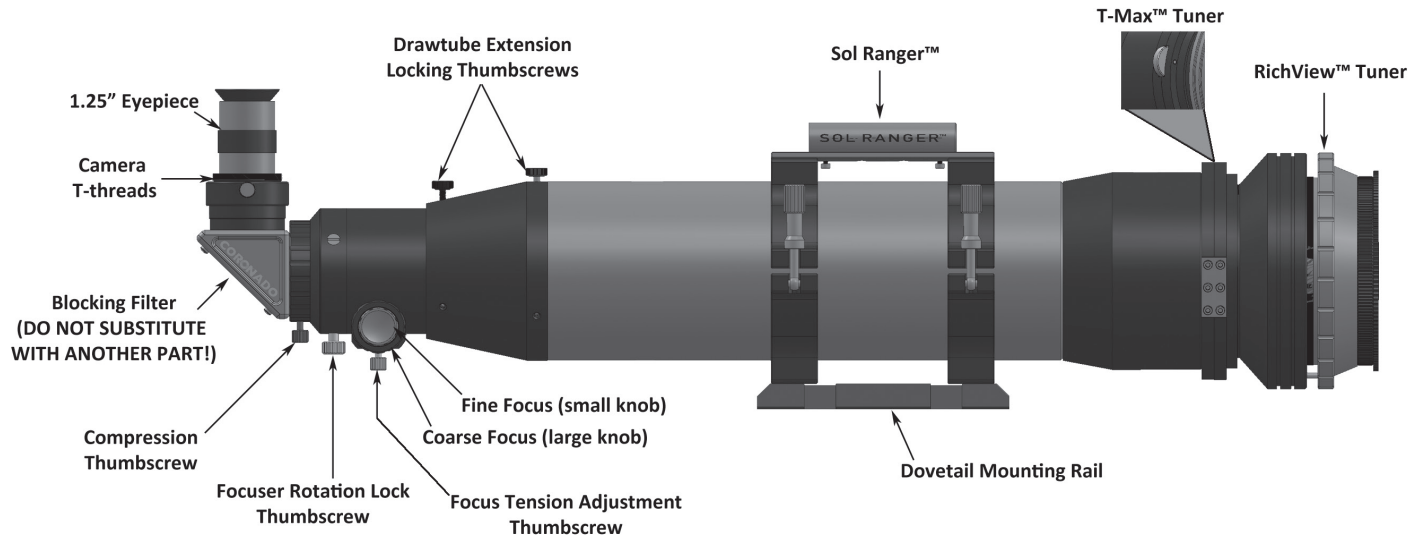

SolarMax[®] III 90 Single Stack Features

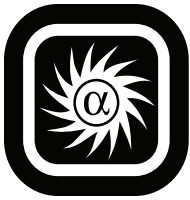

Congratulations on your purchase! Meade Instruments has shipped your Coronado SolarMax III telescope fully assembled and ready for use. Be sure to read the safety and cleaning instructions on page 6 and 15 before using your SolarMax III telescope. Please read

these instructions in full before setting up your new SolarMax III telescope.

Telescope Mounting

The included dovetail mounting rail (#07932) is compatible with most mounts that use the standard Vixen-format dovetail saddle. This includes the Meade LX70 German Equatorial Mount, as well as older models such as the LXD55, LXD75, LX850 and several other mounts in the market.

2" Dual-Speed Focuser

The SolarMax III's high-quality 2" dual-speed rack and pinion focuser allows you to make coarse and fine focusing adjustments when viewing the Sun. Refer to the coarse and fine focus adjustment knobs in the diagram.™

Focus Tension Adjustment

Depending on the eyepiece or camera used, you can optionally adjust the tension on the focuser drawtube to better support the weight on the focuser. Tighten or loosen the Focus Tension Adjustment Thumbscrew as needed. It should not be excessively tight, only enough to hold the drawtube in place when you let go of the focus knobs.

Focuser Rotation Lock

Unlock and safely rotate the position of the blocking filter diagonal to allow the most comfortable viewing position. Relock to a firm feel to prevent unwanted movement while viewing.

Compression Thumbscrew

This locks the BF15/BF30 filter in place. Loosen the thumbscrew to remove or install the BF diagonal as needed. Remember the telescope must be used with the BF filter installed or the incident sun light will not be properly filtered and permanent eye damage may occur.

WARNING!

Do not insert your eyepiece into the blocking filter until you have confirmed that the telescope is securely mounted and all filter elements attached and secured.

Finding the Sun

The included Sol Ranger Sun finder allows you to easily locate the Sun. This finder scope sits on top of the clamshell and allows a small, harmless, ball of light to be projected on to the opaque glass at its back end. By standing back from the Sol Ranger you can easily place this ball of light in the center of the glass and the telescope should be aligned with the Sun - Do not put your eye up to the opaque glass.

Tuning SolarMax® III 90 with RichView and T-Max Tuning System

Because different features on the Sun are moving toward or away from the Earth, their light is Doppler-shifted off the hydrogen-alpha line of 6562.8 Angstroms. You will need to

adjust the tuning slightly to get the best high-contrast views of the features you want to observe. After the SolarMax III telescope is pointed at the Sun and the image has been focused, rotate the RichView™ tuning ring slowly while looking at the image in the eyepiece to get the most detail and contrast. Then, adjust the tilt of the etalon with the T-Max tuner wheel to achieve the brightest image while eliminating any reflections. Surface details will generally require one setting, while prominences will require a different setting for maximum detail.

Double Stacking

A second etalon for a Double Stack system will show increased contrast by narrowing the bandpass to $<0.5\text{\AA}$ and provides a spectacular 3D effect showing increased surface detail. The SolarMax III 90 telescope can be double stacked by adding an additional SolarMax III external etalon. Contact your Coronado dealer or Meade Instruments directly for pricing.

Tuning SolarMax® III Double Stack 90 with RichView™ Tuning System

Start out with both T-Max™ Tuners in the closed position. This is achieved by turning each T-Max™ tuner adjustment wheel clockwise until the gap of the tuner is at a minimum. Also to start, adjust the RichView™ tuner so it is turned counter-clockwise against its hard stop. This is the ideal starting point for the SolarMax® III 90 Double Stack telescope.

After the SolarMax® III telescope is pointed at the Sun and the image has been focused, rotate the T-Max™ tuner located closest to the Sun in the clockwise direction. On page 11, this is labeled as the First T-Max Tuner. Only adjust the tilt of this tuner until any internal reflections are positioned off the image of the Sun and in the least bothersome position. With low magnification eyepieces, it may be difficult to remove the internal reflections completely from the field of view.

When adjusting the tilt on the T-max tuner, keep in mind the least amount of tilt used is best as image quality will begin to suffer with excessive tilt. You only need to adjust the internal reflections to the point where they do not bother your view.

Next, slowly adjust the RichView™ Tuner clockwise until the best contrast is achieved.

Finally, adjust the T-Max™ tuner closest to the eyepiece. On page 11, this is labeled as the Second T-Max™ tuner. Only adjust the tilt of this tuner until the best contrast is achieved and the H- α views you want to see are visible. Keep in mind the least amount of tilt on the T-Max™ tuner used is best.

After these adjustments, you may find it beneficial to go back and re-adjust the RichView™ tuner again to make sure you are seeing the best detail possible.

Blocking Filters

The SolarMax III 90 telescope is available with a BF15 or BF30 blocking filter.

BF15 Models Only

On the BF15 model the solar filters are built directly into the 90 degree diagonal assembly at the rear of the telescope. You **MUST** use the Coronado BF15 diagonal that contains the blocking filter. You cannot substitute another diagonal for the Coronado Blocking Filter Diagonal. This would create an unfiltered system and deliver light from the Sun that will cause damage to the eye. Contact Coronado if you are unsure which version you have.

BF 30 Models Only

On BF30 models, the blocking filter assembly is in the nosepiece of the 90 degree diagonal. The larger 30mm clear aperture on the BF30 is ideal for imaging the Sun and is designed to minimize vignetting and provide a larger useable field of view. From the factory the Coronado BF30 nosepiece is attached to the 90 degree diagonal and is ideal for use with 1.25" Cemax eyepieces.

On BF30 models Coronado also includes a 2" eyepiece holder with removable 1.25" adapter that can be attached to the BF30 nosepiece creating a straight-thru design. This straight-thru design is best used when photographing the Sun as there is no need to image thru the 90 degree diagonal.

To convert the BF30 from the 90 degree diagonal to straight-through design, do the following:

1. Remove the BF30 90 degree diagonal from the telescope.
2. Unthread the 2" nosepiece from the 90 degree diagonal body.
3. Use the included 2" eyepiece holder and thread it onto the BF30 nosepiece. Tighten until firm.
4. Place the BF30 nosepiece into the telescope focuser and secure in place with the 2 locking thumbscrews. If using 2" accessories, remove the 1.25" adapter.

You **MUST** use the Coronado BF30 nosepiece that contains the blocking filter. You cannot substitute another diagonal for the Coronado Blocking Filter Diagonal. This would create an unfiltered system and deliver light from the Sun that will cause damage to the eye. Contact Coronado if you are unsure which version you have.

For both BF15 & BF30mm models, you may have to extend the blocking filter from the focuser slightly to reach focus. The front barrel of the blocking filter is made with extra length to accommodate extending it from the focuser.

The end of the blocking filter diagonal is equipped with T-threads which can thread directly to your astro-imaging camera or T-ring for your DSLR. When using a DSLR, you do not have to extend the blocking filter from the focuser to reach focus.

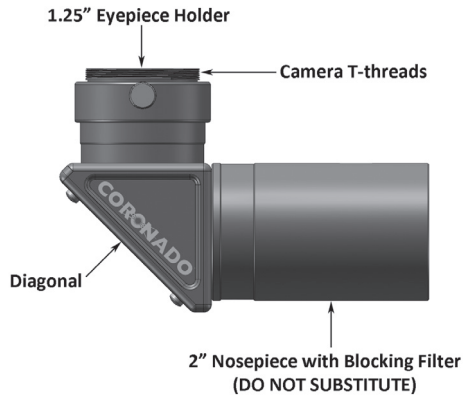

BF30 Blocking Filter in 90° configuration

Imaging & Bino-Viewers

All SolarMax III series telescope will allow for both prime focus and eyepiece projection imaging with standard equipment. Bino-Viewers will also come to focus using a Barlow or optical correcting system. There are many cameras that can be used for imaging.

Thread-on 2\"/>

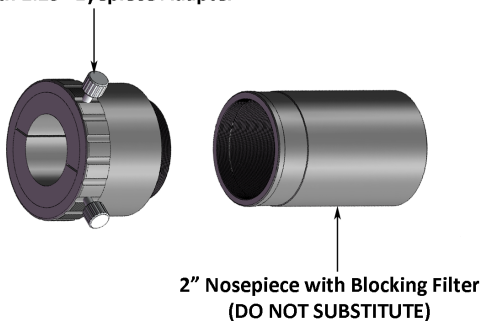

Assembling BF30 Blocking Filter in straight-through configuration

SolarMax III 90 Telescope	
Aperture	90mm
Focal Length	800mm
Focal Ratio	f/8.9
Bandwidth (Single Stacked)	<0.7 Å
Bandwidth (Double Stacked)	<0.5 Å
Thermal Stability	0.005 Å/°C
Blocking Range	Full blocking >10 ⁻⁵ EUV to far IR
Etalon Clear-Aperture	90mm

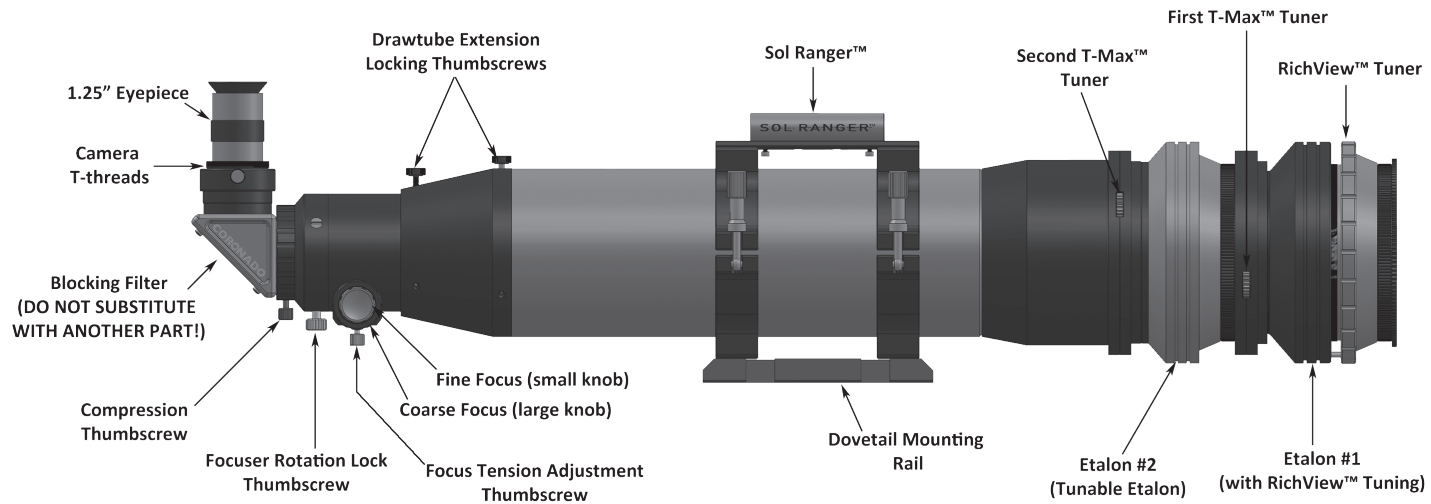

SolarMax® III 90 Double Stack Features

SolarMax III H- α Filter Sets

Congratulations on your purchase of a SolarMax III H- α filter set! Be sure to read the safety and cleaning instructions on page 6 and 16 before using your SolarMax III filter. You can refer to the diagrams below for questions regarding the components of your system. Never point your telescope at the sun until your filter set is fully assembled on the telescope. Please read these instructions in full before setting up your new filter set.

Before purchasing any of the accessories listed below please contact Meade customer service for guidance regarding correct selection and mounting.

Mounting to Your Telescope

With the exception of a few refractors, mounting will typically require a custom adapter plate to mount the etalon filter to your telescope. Meade does not manufacture or supply these adapters and is not responsible for the performance and safety of our filters when used with these adapter plates. When mounting Coronado filters on telescopes other than Coronado SolarMax III telescopes, the user assumes the responsibility for the correct mounting and safety of the system.

Never point your telescope at the sun until your filter set is fully assembled on the telescope. Your telescope should be fully mounted and pointing away from the Sun while attaching the filters. The etalon is designed to be mounted on the objective lens of your telescope either directly or via an adapter plate. Make sure that the etalon is fully threaded into the adapter plate or telescope objective cell.

Blocking Filters

This is an essential component of your H- α set up and must be installed for the system to work and be safe to use:

BF15 - The blocking filter is housed in a 1.25" right angle diagonal with 2" nosepiece. Slide the 2" barrel into the focuser and secure in place. If you have a 1.25" focuser you will need a reducer or adapter to 1.25". Call Coronado for details on obtaining this adapter.

BF30 - The BF30 blocking filter is designed for use with telescopes of focal lengths from 1,500mm to 3,000mm. Slide the BF30 nosepiece tube into the focuser and secure it in place. Coronado recommends using 1.25" eyepieces for visual work. Some 2" accessories may not come to focus and are not recommended. Most 2" eyepieces have many lens elements which may cause excessive internal reflections when viewing the Sun.

Tuning with RichView™ and T-Max™ Tuning System

Because different features on the Sun are moving toward or away from the Earth, their light is Doppler-shifted off the hydrogen-alpha line of 6562.8 Angstroms. You will need to adjust the tuning slightly to get the best high-contrast views of the features you want to observe. After you install the SolarMax III Etalon Solar filter and blocking filter onto your telescope and have covered all non-filtered optical components such as viewfinder and accessories you are now ready to point the telescope at the sun. Center the Sun in the filtered telescope and adjust the focus until the Sun's edge is sharp. Now rotate the RichView™ tuning ring slowly while looking at the image in the eyepiece to get the most detail and contrast. Then, adjust the tilt of the etalon with the T-Max tuner wheel to achieve the brightest image while eliminating any reflections. Surface details will generally require one setting, while prominences will require a different setting for maximum detail.

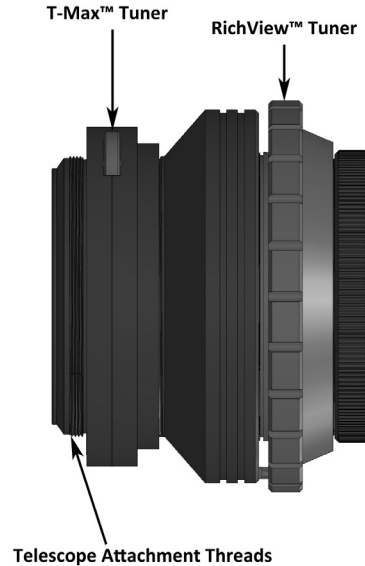

SolarMax® III Etalon with RichView™ Tuning

Double Stacking

This greatly increases contrast by narrowing the bandpass to $<0.5\text{\AA}$ and gives a spectacular 3D effect showing increased surface detail. The SolarMax III filters can be double stacked by adding an additional SolarMax III Etalon with T-Max™ of the same aperture. Contact your Coronado dealer or Meade Instruments directly for pricing.

Eyepieces

The best eyepieces for solar viewing are Coronado's CEMAX™ contrast enhanced series eyepieces. Conventional eyepieces can also be used. An eyepiece with high-quality anti-reflection coatings and/or with fewer lens elements can help reduce unwanted internal reflections.

Dark Cloth

One easy way to reduce incidental light from entering your eye is to use a dark cloth to completely cover your head and the eyepiece. The inside should be black but a reflective surface on the outside is recommended to avoid heat buildup.

Location

One of the benefits of owning a Coronado solar observing set up is the portability of the system. For optimal seeing avoid setting up on heat reflective surfaces such as concrete or tarmac. Grass, water, or low trees are your best surroundings for viewing.

WARNING

Do not insert your eyepiece into the blocking filter until you have the telescope securely mounted and the SolarMax III element attached and secured.

Filter Type	Interference filter with hard non-degradable coatings
Aperture	90mm clear aperture
Bandwidth (Single Stacked)	$<0.7\text{\AA}$
Bandwidth (Double Stacked)	$<0.5\text{\AA}$
Thermal Stability	$0.005\text{\AA}/^{\circ}\text{C}$
Blocking Range	Full blocking $>10^{-5}$ EUV to far IR

Cleaning

Should your filter get a build up of loose dirt particles on any surface use a static free lens brush to gently “sweep” it clean. Fingerprints and other residue can be cleaned using a high grade optical solution applied to an optical tissue. Using a circular motion work from the outside edge in towards the center. As these are hard coatings you can be firm but do not rub. Finish with an anti-static lens cloth. All of these cleaning items can be purchased through a camera/telescope dealer.

Never use the following items on any section of your filter.

1. Compressed Air
2. Acetone
3. Anything with acidic properties
4. Any fabric not intended to clean optical coatings
5. Household cleaners

If you have questions please contact our customer support.

Care

The telescopes and filters, if used properly, will not degrade with exposure to the Sun’s rays. You may leave your system set up in the Sun, even tracking the Sun, all day without risk. When your system is not being used it should be stored in a cool, dry location in the foam-lined case it was shipped in and with the included protective caps securely in place. In locations with excessive humidity placing a silica packet in the box is advised. Provided you do not drop or subject the telescope or filter to rough handling, it will work as well years from now as it does today. We use hard coatings throughout the system to ensure uniform performance for years to come. It is safe to carry your filters on airplanes and to pass them through X-Ray machines.

Additional Support and Accessories

Additional support and accessories are available at <http://www.meade.com/solar/solar-scopes.html>. There you can browse different accessories, or download a replacement instruction manual.

CEMAX Eyepieces - The best eyepieces for H- α observing. These are the only eyepieces built specifically to have their peak transmittance at H- α . Using optimized coatings to enhance contrast and minimize glare, we have set the standard for the market. Available in 25mm, 18mm, 12mm, and a 2x Barlow, 20mm eye relief, 52 degree FOV. You will see the difference! Call or see our website for package deals.

Definition of Terms

Prominences — H- α emissions projecting beyond the limb of the sun, consisting of complex clouds or streamers of ionized hydrogen above or in the Chromosphere.

Filaments - Prominences seen against the face of the sun, appearing as long narrow dark streamers or diffuse dark areas.

Active Region - Active regions are the result of enhanced magnetic fields and appear darker than the surrounding areas with a roughly circular shape. Active regions show plage, sunspots, and flares.

Plage - Patchy H- α brightening on the solar disk, usually found in or near active regions, which can last for several days. These are found in areas of nearly vertical emerging or reconnecting magnetic lines.

Sunspots - Spots of varying size usually consisting of a dark central region (umbra) and a lighter halo consisting of many short fine fibrils (penumbra).

Flares - A sudden eruption of energy in the solar atmosphere lasting minutes to hours, from which radiation and particles are emitted.

Chromosphere - An incandescent, transparent layer of gas, primarily hydrogen, several thousand miles in depth, lying above and surrounding the Photosphere of the Sun and beneath the transition region of the Corona.

FOV - Field of View. This describes, in degrees, the area of sky one can see when looking through the eyepiece.

OTA - Optical Tube Assembly. This is the main body of a telescope.

H- α - A wavelength of light at 656.3nm or 6562.8 Angstroms (1nm = 1 billionth of a meter)

Angstrom - A unit of measurement for the wavelength of light. (1Å = 0.1nm)

Bandpass - A filter's bandpass tells how wide a region of the light spectrum is transmitted around the primary wavelength. The narrower the bandpass, the more surface detail becomes visible on the Sun. You can further narrow the bandpass of your primary single stack filter by adding an additional filter of the same size to the objective. The term "double stacking" is used to describe this process.

E.R.F. - Energy Rejection Filter. Prevents UV and IR light from entering the telescope.

Etalon - The heart of a Coronado filter. Composed of optics with tolerances 4 times tighter than those used in the Hubble telescope.

Granulation - Small scale convective cell structures visible in white light ("rice grains"), best seen in apertures over three inches, and in green light. Each cell consists of a brighter polygonal area of hot rising gas typically about 1100 km across, and a cooler edge or "channel" of descending gas about 230 km wide.

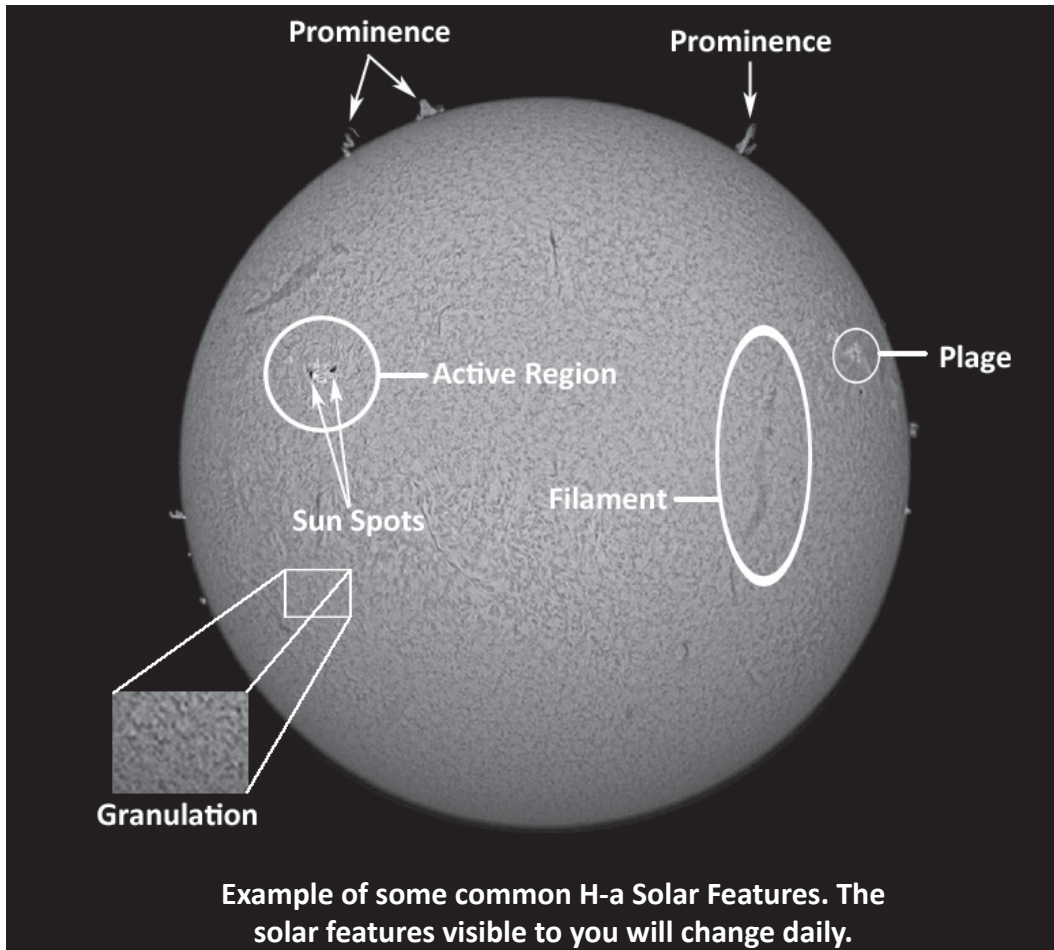

Example of some common H-a Solar Features. The solar features visible to you will change daily.

Solar Facts

The Sun is on average 93 million miles (150 million km) away from Earth and 900,000 miles (1.4 million km) across.

The Earth is about 8,000 miles (13,000 km) across.

Think of the Sun as a basketball and Earth as pin head and you have the proper proportions.

It takes a little over 8 minutes for light from the Sun to reach Earth.

Approximately 1 million Earths would fit inside the Sun.

Solar radius = 695,990 km = 432,490 mi = 109 Earth radii

Solar mass = 1.989×10^{30} kg = 4.376×10^{30} lb = 333,000 Earth masses

Solar luminosity (energy output of the Sun) = 3.846×10^{33} erg/s

Surface temperature = 5790 K = 10,400 °F

Surface density = 2.07×10^{-7} g/cm³ = 1.6×10^{-4} Air density

Surface composition = 90% H, 28% He, 2% (C, N, O, ...) by mass

Central temperature = 15,600,000 K = 28,000,000 °F

Central density = 150 g/cm³ = 8x Gold density

Central composition = 35% H, 63% He, 2% (C, N, O, ...) by mass

Troubleshooting

Solar observing is a unique aspect of the telescope hobby and there are a few things to keep in mind and tricks that may assist in the early outings, even for those who may have owned one or more traditional night time telescopes:

Locating the Sun: Sometimes the single hardest thing for new owners to master is the simple act of locating the brightest object in the sky. One pro tip is to simply look at and minimize the shadow of the telescope on the ground. Flat level ground like a sidewalk will make this easier.

Be sure to use the lowest power/widest field eyepiece available also just to make finding the Sun easier- you can then switch to higher magnification. The Meade PST has a built in Sun finder while Coronado III models come with the Sol Ranger™ finder, also available separately for those purchasing a Coronado filter set only.

GOTO and Tracking: Meade AutoStar or AudioStar equipped mounts and telescopes can be “mock aligned” in the daytime by simply doing a standard Meade one star alignment. Although the stars themselves will obviously not be visible in broad daylight, this pseudo-alignment will allow motorized tracking of the Sun, while selecting Mercury from the database after the mock alignment should take the scope to the near vicinity of the Sun itself. You can then center the Sun using the keypad arrow keys.

The image isn't focused: Make sure that the drawtube(s) have been extended. The first thing to look for is a sharp disk which is easiest to determine by examining the edges of the Sun. Step Two is to use the T-Max™ tuner to minimize or remove any ghost image. Step Three is to use the H- α tuning on the scope to enhance the visible detail on the disk, prominences, and any specific features of interest. If, however, the disk is very sharp but without any discernable detail whatsoever it is possible that the image in the eyepiece is actually a ghost image of the Sun and the Sun itself is in fact completely outside the field of view of the eyepiece. Double check to be sure the Sun is actually in the very center of the Sol Ranger and if needed move the telescope slightly in a search pattern to find the actual Sun. The difference between a ghost and the actual Sun will be immediately obvious once seen the first time.

Detail: Many observers report that with time and experience their own perception of detail becomes more acute. H- α light is very far into the red end of the spectrum and our eyes are not, initially, very sensitive to this. The more you view the more you may find you perceive additional detail more easily. Blocking stray light with a hat or even complete head covering (observing cloth) blocking all ambient light can actually make a great difference and we definitely recommend giving it a try. As with any telescope observing conditions will vary greatly from day to day, changing the level of detail you can see. Additionally of course the Sun itself is an ever changing object unlike the vast majority of celestial targets with changes in the surface features and prominences taking place over the course of mere hours or even minutes. Be sure to observe often and we hope you greatly enjoy the experience of taking in the wonder of the unique and highly dynamic center of our Solar System.

Meade Instruments Corp. Warranty for Coronado Products

Meade Instruments Corp.
27 Hubble, Irvine, CA 92618

Phone: 800-626-3233

Thank you for your purchase of a Meade Instruments' CORONADO product. Upon receiving your instrument, please examine it thoroughly. Notify your supplier immediately should any visible signs of exterior damage to the package be present. This filter was field tested and rigorously evaluated before leaving the factory. It is important that you sign, where indicated, and submit the applicable portion of this warranty form within 30 days of the noted date shipped and/or receipt from a dealer, to the address shown above. Make sure to keep a copy for your records. Failure to return the warranty form portion within thirty (30) days of RECEIPT DATE of filter will render this warranty VOID.

Meade Instruments Corp - Coronado limited Warranty

Meade Instruments Corp warrants the product against defects in materials and workmanship for a period of sixty (60) months from the date of delivery. Once accepted by the Customer and the warranty form returned, the filter will be considered to be in good working order. Any subsequent de-contacting of the Fabry-Pérot etalon within the filter system, is not covered by this warranty nor is any other subsequent damage to the blocking filter. Any modification, alteration, disassembly, damage to or tampering with the PRODUCT or any of its components will void the warranty, and, MAY MAKE USE OF THE INSTRUMENT UNSAFE.

Please review WARNING contents below.

RGA Number Required: Prior to the return of any product or part, a Return Goods Authorization (RGA) number must be obtained from Meade by writing or calling 800-626-3233 (800-62-MEADE). Each returned part or product must include a written statement detailing the nature of the claimed defect, as well as the owner's name, address and phone number.

RETURN OF THE PRODUCT IN ANY OTHER TYPE OF PACKAGING, OTHER THAN THE ORIGINAL AS SUPPLIED BY MEADE INSTRUMENTS, WILL VOID THE WARRANTY.

The warranty set forth above shall be IN LIEU of any other warranty, expressed or implied, including, but not limited to, any implied warranty of MERCHANTABILITY or fitness, for a particular purpose.

WARNING: UNDER NO CIRCUMSTANCES SHOULD THE USER ATTEMPT TO DISASSEMBLE OR REMOVE ANY PART OF THE PRODUCT.

THE FILTER HAS BEEN SEALED AFTER FINAL TESTING AND HAS BEEN CONSTRUCTED TO PERMIT SAFE SOLAR VIEWING. ANY ALTERATION, DISASSEMBLY, DAMAGE OR TAMPERING TO THE PRODUCT WILL COMPROMISE ITS SAFETY, VOID THE WARRANTY AND, MAY RESULT IN PERSONAL INJURY. IF THE PRODUCT IS TO BE USED IN CONJUNCTION WITH OTHER OPTICAL INSTRUMENTS, IT IS IMPERATIVE THAT ALL OPTICS OF SUCH OTHER INSTRUMENTS BE FULLY COVERED TO AVOID ACCIDENTAL VIEWING THROUGH THOSE INSTRUMENTS. WE RECOMMEND THAT THE USER EMPLOY A SOLAR VIEWING CHECKLIST SO AS TO AVOID ACCIDENTAL MISUSE OF THE PRODUCT, WHICH MAY RESULT IN PERSONAL INJURY.

Date shipped: _____ Serial number: _____

Complete this form; make a copy for your records and mail to Meade Instruments Corp. 27 Hubble, Irvine, CA 92618

Serial number: Date shipped: _____

Please refer to the numbers above in any type of correspondence Date received: _____

Purchased from: _____

Name (please print): _____

Address: _____

How did you learn of this product?: _____

Telephone: _____ Email: _____

Signature: _____

This warranty gives you specific rights.

You may have other rights which vary from state to state

Clip-out along dashed line.



CORONADO[®]

A Meade Instruments Company

2017 Meade Instruments Corp. reserves the right to change product specifications or to discontinue products without notice.

14-2686-90 REV 0

