

INSTRUCTION MANUAL

X-Wedge for LX200 and LX600 telescopes



MEADE INSTRUMENTS

Innovative products for curious minds

since 1972

X-WEDGE OPERATING MANUAL

This Meade X-Wedge is designed for use with the Meade Giant Field Tripod.

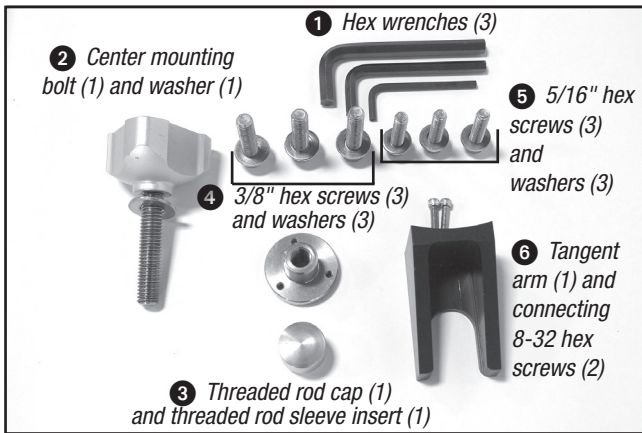

Figure A. Hardware kit for the X-Wedge.

Warning: If the telescope is placed on the wedge without the field tripod attached to it, the wedge will be seriously overbalanced and the telescope could tip over.

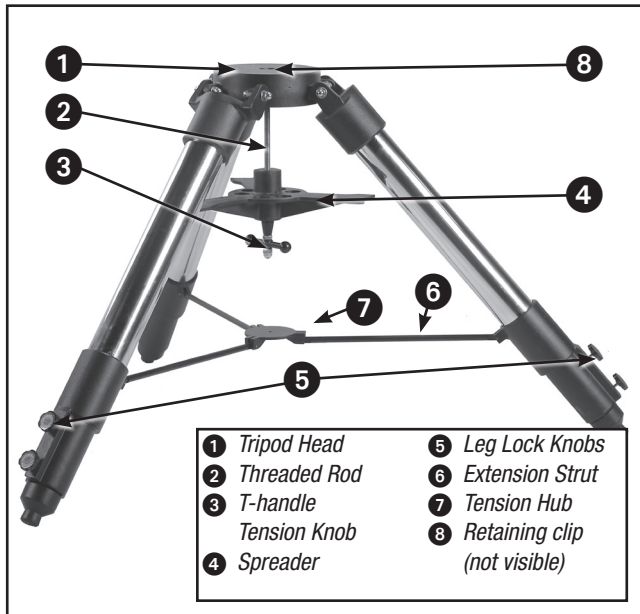

Figure B. Fully assembled tripod.

The X-Wedge instructions are written for use with either the Meade Standard Field or Giant Field Tripod. The assembly procedure requires two people who can lift about 55 pounds each.

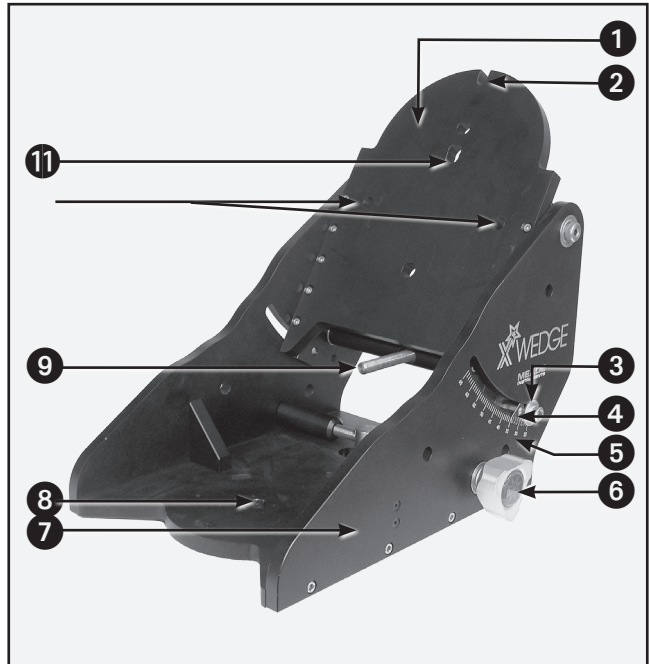

Figure C. Parts of the X-Wedge. (1) Tilt-plate; (2) Mounting slot at top of tilt plate; (3) Latitude lock screw (one on each side); (4) Vernier pointer; (5) Latitude Scale; (6) Azimuth Control Knob; (7) Wedge Body; (8) Plate center hole; (9) Latitude control screw (adjustment knob not shown); (10) Mounting slots; (11) Center bolt hole.

X-Wedge Assembly

The required wedge hardware is shipped within the wedge carton (**Fig. A**).

1. Locate the two 8-32 hex screws and the tangent arm (**Fig. A, 6**).



Figure D. Attach the tangent arm with the flat surface facing up.

2. Attach the tangent arm to the tripod using the supplied 8-32 hex screws. Note: the flat surface of the tangent arm should face upwards (**Fig. D**).

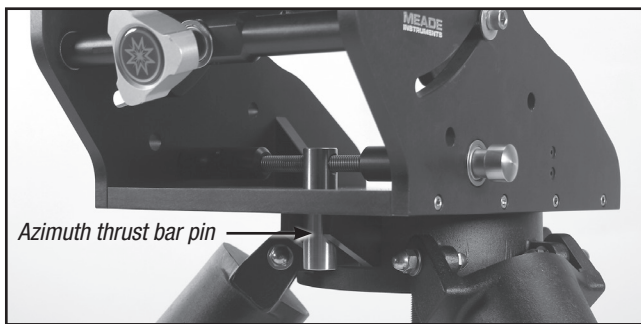

Figure E. The azimuth thrust bar pin positioned in the tangent arm.

3. Place the wedge on the tripod head, sliding the azimuth thrust bar pin into the tangent arm slot (**Fig. E**).
4. Push the tripod threaded rod (**Fig. B, 2**) up so that the rod extends through the X-Wedge plate center hole (**Fig C, 8**).
5. Screw the threaded rod insert onto the threaded rod until it is seated firmly on the X-Wedge base plate, fitted in plate center hole (**Fig. F**).

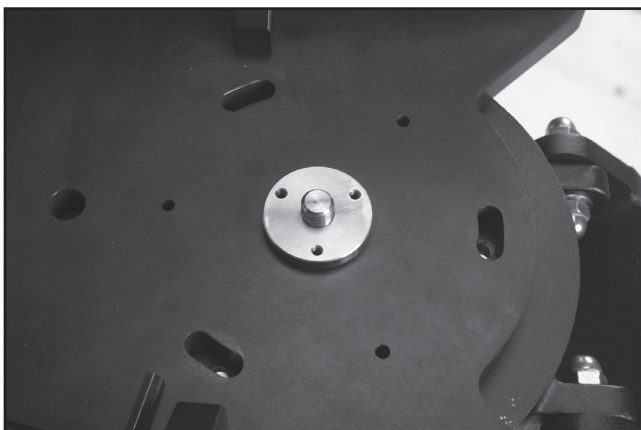

Figure F. The Threaded rod insert properly positioned on the threaded rod and X-Wedge base plate.

6. Align the tripod spreader bar with the tripod legs as shown in **Fig. B**. Tighten the tripod t-handle tension knob to a snug fit. Screw the threaded rod cap onto the end of the threaded rod.
7. Using the three 5/16" hex screws and washers (**Fig. A, 5**) pass the hex screws through the oval slots on the wedge floor and thread them into the tripod head (**Fig. G**).
8. The latitude lock screw (**Fig. H**) is installed at the factory to allow the tilt plate to be adjusted for any latitude greater than 25° and less than 57°. If viewing in a region with a latitude from 57° to

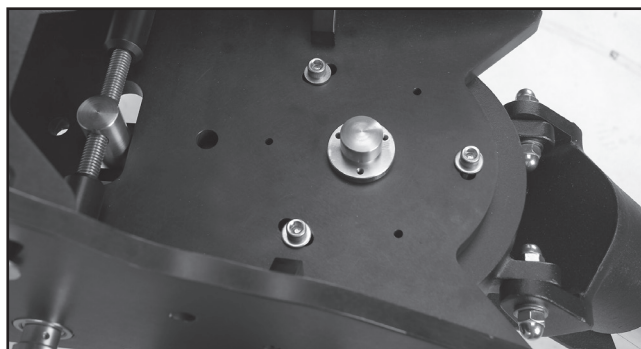

Figure G. X-Wedge with threaded rod cap and 5/16" hex screws secured.

65°, unthread the the lock screw with the supplied hex key wrench and move the screw to the optional mounting hole.

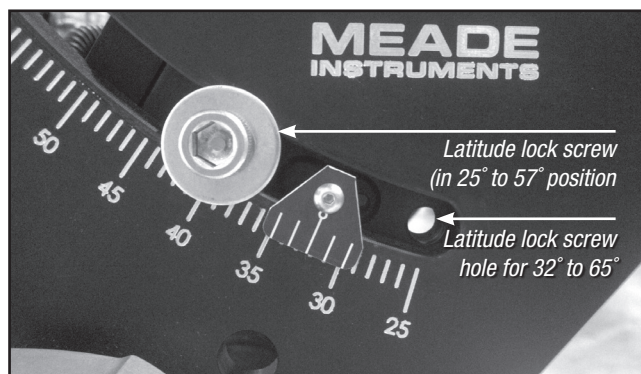

Figure H. Latitude screw with multiple lock screw positions.

Mounting the Telescope on the X-Wedge

1. Thread one of the provided 3/8" hex screws into the hole on the underside of the telescope drive base. The desired hole is located at the curved



Figure I. Attach one of the 3/8" hex screws to the curved part of the telescope drive base.

end of the telescope drive base (see Fig. I). Be sure to leave approx, 3/4" of the screw exposed to allow for clearance of the wedge tilt plate.

2. Grasp the two fork arms of the telescope firmly, with the control panel toward the floor, place the telescope onto the wedge tilt plate (Fig. A, 1) by sliding the mounting screw on the telescope base into the slot at the top tilt plate (Fig. J).
3. Insert the center mounting bolt (Fig. K) through



Figure J. The telescope drive base placed on the X-Wedge tilt plate.

the center of the underside of the tilt plate and into the underside of the drive base. Firmly tighten the bolt. Do not overtighten.

Note: It is important to insert the center mounting bolt into the wedge-telescope assembly. The center mounting bolt insures the precise pointing accuracy of the X-Wedge.

4. Insert the two remaining 3/8" hex screws



Figure K. Attaching the center mounting bolt.

through the underside of the tilt plate (Fig. L) and into the underside of the drive base. Firmly tighten all three 3/8" hex screws at this time. Do

not overtighten.

The telescope is now fully mounted onto the wedge and field

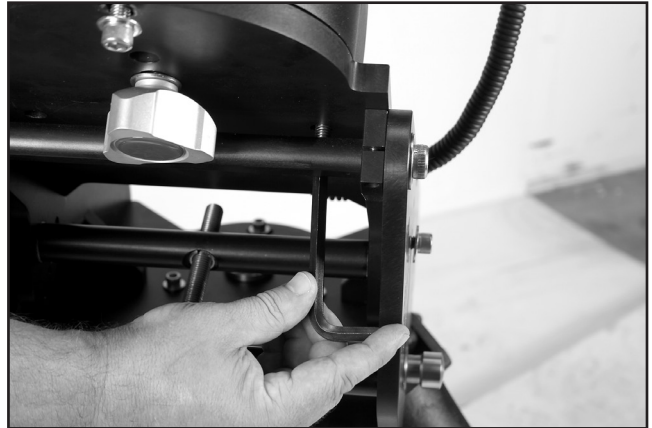

Figure L. Use the provided hex wrench to secure the three 3/8" hex screws into the telescope drive base.

tripod. Adjustments in wedge latitude angle and/or azimuth orientation may be made with the telescope in place.

Setting the Observing Latitude

Look up the latitude of the desired observing site (most road maps show latitude lines). Then, loosen the latitude lock screws (Fig. C, 3) and rotate the fine latitude control knob (Fig. C, 9) while reading the latitude scale (Fig. C, 5). The latitude pointer is a vernier scale (Fig. C, 4) which will allow the tilt angle to be set to within 0.25°. When the tilt plate is aligned with the desired latitude, tighten the latitude locking screws.

Aligning on Polaris

Begin aligning the telescope by locating Polaris. Finding Polaris is simple. Most people recognize the "Big Dipper. The Big Dipper has two stars that point the way. Polaris is the last star in the "handle" of the Little Dipper (Fig. M).

Once you have located Polaris in the sky, orient your telescope

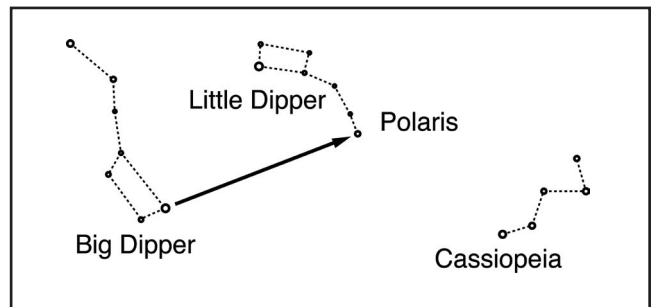

Fig. M. Locating Polaris

so that the control panel faces north (towards Polaris). You may need to pick-up and rotate the telescope on its tripod to achieve this orientation. The telescope and X-Wedge are now pointing very near to the celestial north. Loosen the DEC lock, rotate the OTA so that it is 90 degrees to the base (pointing towards Polaris) and then relock the DEC. If you were to have performed this maneuver perfectly, you would be able to see Polaris through the finder scope (make sure that you aligned the finderscope to the OTA). If you cannot, rotate the entire telescope/tripod assembly until you can.

You are now ready to perform one of the AutoStar equatorial alignment procedures. Consult your telescope's instruction manual for exact details.

Aligning the Magnetic Compass

With the aid of the magnetic compass, a telescope can be polar aligned in locations where the view of Polaris is obstructed or even before the skies get dark. The compass face has an angular scale from 0 to 360 degrees which will be useful in adjusting for the local angle of Magnetic Declination—the difference between Magnetic North (which the compass shows) and true north (where the telescope should be pointed).

Note: *Magnetic Declination should not be confused with the astronomical term “Declination” which, when used with “Right Ascension,” describes the celestial coordinate system.*

1. Setting Magnetic Declination:

- a. In order to obtain an accurate reading using the compass, you first need to determine the Magnetic Declination of the observing area by referring to the Magnetic Declination Map (**Fig O**). Locate this value on the compass face for future reference.

NOTE: *East Magnetic Declination means True North is to the right of the Magnetic North position and West Magnetic Declination means True North is left of the Magnetic North position. For example, **Fig. O** shows the correct setting for 13.5° East Declination which covers Irvine, CA. The compass scale markings range from 0 to 360 degrees azimuth so for East Magnetic Declinations subtract the East Magnetic Declination value from 360 to obtain the correct reference mark on the compass face.*

- b. While holding the compass, rotate it so the red compass arrow points in the direction of Magnetic North. The arrow should be directly over the "N" marking on the compass face.
- c. Now place the compass onto the flat base

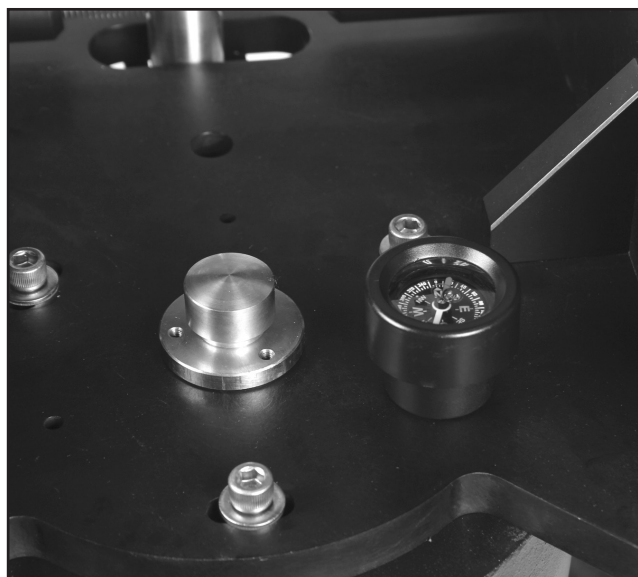

Figure N. *Compass level placed on the X-Wedge.*

of the X-Wedge as shown in **Fig N**. Verify the compass is still pointing toward Magnetic North and the bubble level is properly centered. If the bubble is not centered, adjust the tripod legs until centered.

2. Finding True North:

The magnetic compass is now ready for use. Follow these simple steps for a quick and easy azimuth alignment.

- a. Slightly loosen the three 5/16" hex screws in the wedge floor to allow for rotation of the X-Wedge.
- b. Using the Azimuth Control Knob (**Fig C, 6**), manually adjust the X-wedge around the



Figure O. *Compass bearing adjusted for Irvine, CA's magnetic declination.*

threaded rod (without moving the compass) until the red compass arrow points toward the observing sites Magnetic Declination found in step 1.

c. Tighten the t-handle tension knob, locking the X-Wedge into place.

d. Retighten the 5/16" hex screws on the wedge floor. Do not over tighten.

The tripod and X-Wedge are now pointed very near celestial north and ready to run one of the alignment procedures.

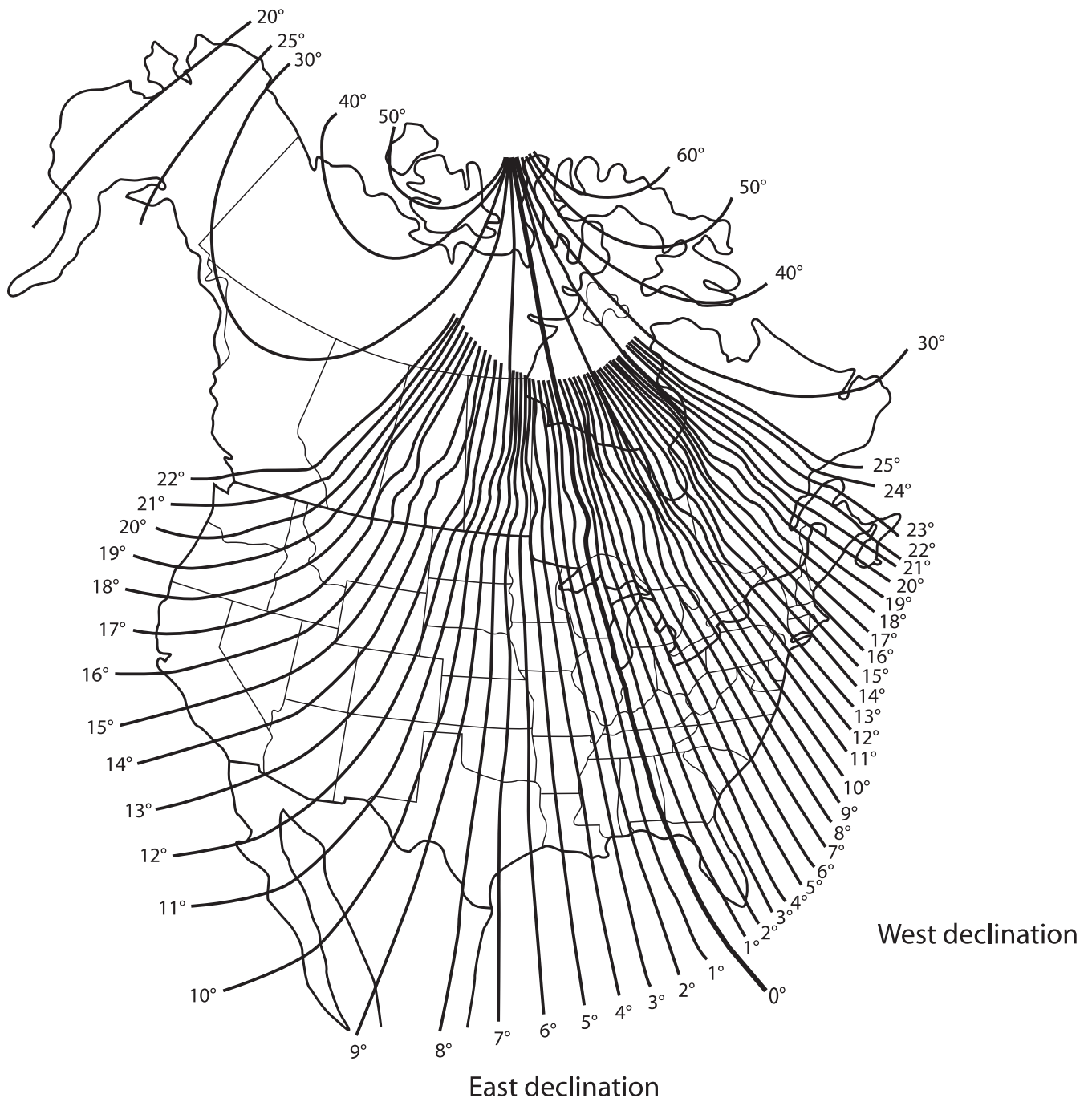

Figure P. Magnetic declination map of North America.

MEADE LIMITED WARRANTY

Every Meade telescope, spotting scope, and telescope accessory is warranted by Meade Instruments Corp. ("Meade") to be free of defects in materials and workmanship for a period of ONE YEAR from the date of original purchase in the U.S.A. and Canada. Meade will repair or replace a product, or part thereof, found by Meade to be defective, provided the defective part is returned to Meade, freight-prepaid, with proof of purchase. This warranty applies to the original purchaser only and is non-transferable. Meade products purchased outside North America are not included in this warranty, but are covered under separate warranties issued by Meade international distributors.

RGA Number Required: Prior to the return of any product or part, a Return Goods Authorization (RGA) number must be obtained from Meade by writing, or calling (800) 626-3233. Each returned part or product must include a written statement detailing the nature of the claimed defect, as well as the owner's name, address, and phone number.

This warranty is not valid in cases where the product has been abused or mishandled, where unauthorized repairs have been attempted or performed, or where depreciation of the product is due to normal wear-and-tear. Meade specifically disclaims special, indirect, or consequential damages or lost profit which may result from a breach of this warranty. Any implied warranties which cannot be disclaimed are hereby limited to a term of one year from the date of original retail purchase.

This warranty gives you specific rights. You may have other rights which vary from state to state.

Meade reserves the right to change product specifications or to discontinue products without notice.

Meade Instruments Corp.
27 Hubble
Irvine, CA 92618
800-626-3233

14-2118-00 071112
55-12003

www.meade.com

Follow us on facebook and twitter for updates.



MEADE® INSTRUMENTS

Innovative products for curious minds

since 1972