

OPTICSTAR ARC-127 QUAD REFRACTOR

127mm F4.9 Achromatic Quadruplet Photo-visual Refractor



Owner's Manual

OPTICSTAR

WARNING!

DO NOT USE THE TELESCOPE TO LOOK AT THE SUN!

LOOKING AT OR CLOSE TO THE SUN WITH A TELESCOPE OR FINDERSCOPE WILL CAUSE INSTANT AND PERMANENT DAMAGE TO YOUR EYES. CHILDREN SHOULD AT ALL TIMES BE SUPERVISED BY A RESPONSIBLE ADULT WHILE OBSERVING.



Do not disassemble your telescope, there are no user serviceable parts inside. Disassembling the lens cell will invalidate your warranty.

Opticstar Ltd
87 Washway Road, Sale, Greater Manchester M33 7TQ United Kingdom
WEB: www.opticstar.com - EMAIL: info@opticstar.com

Introduction

Congratulations on the purchase of your Opticstar ARC-127 QUAD achromatic refractor. The ARC-127 QUAD telescope is very well suited for astronomical observation and imaging. Its advanced optical design, fully coated achromatic optics, solid construction, metal knife-edge baffles and short focal length make it ideal for high and low power work whether it is viewing the Moon and planets or extended deep sky objects.

Please read through the manual to familiarise yourself with the telescope so that you can get the most out of the equipment. This manual details the setting up, operation, specification and optional accessories of the Opticstar ARC-127 QUAD telescope.

Parts

The Opticstar ARC-127 QUAD telescope package consists of the following:

1. Optical Tube with rings and dovetail.
2. Finder scope with Bracket
3. 1.25" Star Diagonal
4. 25mm Plossl eyepiece
5. This Manual

Mounting the Telescope

The telescope is fitted with a Vixen type dovetail platform and will mount on most telescope mounts including the Opticstar EQ1300 GT computerised mount.

The telescope can be mounted as is on an extra heavy duty photographic tripod with a heavy photographic thread. Heavy heads will work adequately at low magnifications, an extra heavy duty geared head with slow-motion controls is required for higher magnifications or when fine control is required.

Finder-scope Assembly and Alignment

To assemble the finder-scope place the finder-scope optical tube in the supplied bracket and lightly tighten the six thumbscrews enough to secure the finder-scope optical tube in place as in the picture on the right. Please note that two of the six thumb screws are spring loaded. Once you set the spring loaded screws to the desired position you would only need to adjust the four remaining thumb screws to align the finder scope as outlined in the following page.

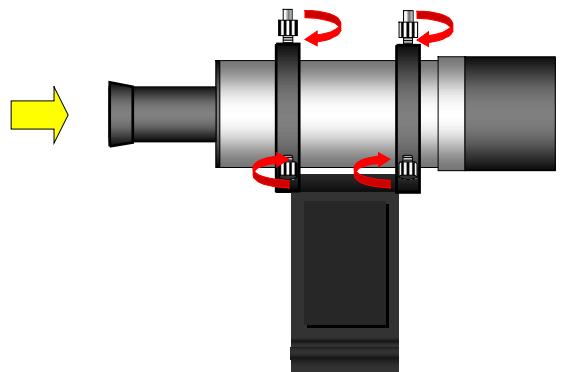

Once Mount the assembled finder-scope to the telescope and secure it in place. Attach the telescope to a mount/tripod.

The finder scope has been focused at infinity at the factory. If there was a need to refocus the finder scope you can do so as follows:

1. Dismount the finder scope from the telescope and remove it from its bracket.
2. Release the Locking Ring by turning it several times.
3. Point the finder scope to your target i.e. star at 'infinity'.
4. Turn the Objective Cell to bring the star in sharp focus.
5. Secure the Objective Cell position by tightening the Locking Ring against it.
6. Re-assemble and mount the finder scope to the telescope.

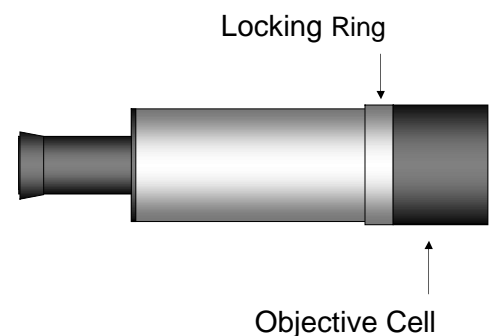

To align the finder-scope perform steps 1 through 9 as outlined below, we recommend that the telescope is first aligned during daytime. Please note that the view would appear mirrored and/or flipped depending on your arrangement.

1. Attach the finder-scope to the telescope.
2. Mount the telescope to a photographic tripod or astronomical mount.
3. Attach the supplied 1.25" astronomical diagonal to the telescope and secure it in place.
4. Place a low power (i.e. 25mm) eyepiece in the telescope's diagonal, secure it in place.
5. Loosen the movement locks of your mount/tripod, this will allow the telescope to move freely.
6. Point the telescope to a distant land object a few miles away (i.e. the top of a lamp post, tree or chimney). You will notice that the image will be mirrored and/or upside down, this is normal for an astronomical telescope.
7. Turn the focuser knob to bring the target in focus and centre the object in the eyepiece.
8. Re-tighten the tripod/mount movement locks so that the telescope remains stable during the finder-scope alignment procedure.
9. Look through the finder-scope.
10. Use the collimating thumb-screws on the finder-scope's bracket to align the finder-scope so that the cross-hair is precisely over the same object in the eyepiece. You only need to use the three thumb-screws on a single ring to align the finder-scope.



The finder-scope is now aligned to the main telescope. You can check and refine alignment on a night sky object like a star if required. Please note that the view will not be the right way up and views will differ depending whether a diagonal is used or not. If you do not use a diagonal you may need an extension tube to reach focus.

Using the ARC-127 QUAD

If you are new to observing it is advisable to first use the telescope during daytime to learn how it operates. First mount the telescope on a tripod or telescope mount. Once the optical tube has been mounted attach the finder-scope, then attach a diagonal and low power eyepiece i.e. 25mm. Make certain that all parts are secure.

Simply choose a distant target to observe like a large building or large tree. Point the telescope towards the target so that it roughly lines up with the target.

Look through the finder-scope, if you have not aligned it already this is a good time to do so before you proceed. Move the telescope until the target is visible in the finder-scope and positioned under the cross-hair.

Once the object is lined up in the finder-scope you will be able to observe the target through the telescope's eyepiece. Look through the eyepiece, turn the focuser knob to bring the target into focus.

Terrestrial Observation

You can use the telescope for terrestrial observation for which you need a prism diagonal, otherwise the image will appear mirrored and/or upside down. In astronomy it is not relevant if the Moon is say upside down, what is important is to capture as much light as possible and correctors take some of this valuable light away.

Please note that this is a heavy and large telescope and as such it is difficult to manage on a tripod. As such we recommend the heaviest duty tripods and tripod heads.

Astronomical Observation

When observing at night your first target should be the Moon as it offers a wealth of detail; it is large, bright and easy to locate. Spend some time with the Moon, high magnifications will show many interesting features. You will see mountain ranges, craters and evidence of volcanic activity when the Moon was mainly composed of melted rock. You will need a neutral density filter to observe the Moon, a 13% transparency filter is recommended.

Once confident with the Moon the planets would be the next target. Planets are easy to identify as they are bright and do not twinkle unlike stars. Please note that when a planet is out of focus and it becomes very dim you may not be able to see it.

Use the finder-scope to place the planet in the centre of the field of view, then look through the eyepiece and use the telescope focuser to bring the planet into focus. Planets that are easy to observe include Venus, Mars, Jupiter and Saturn. You will get the most out of the planets at higher magnifications.

At high magnifications planets will look like marbles and will reveal a high degree of detail to the trained eye. Jupiter will show banding, the Red Spot and you will also be able to observe the Galilean Moons.

Saturn is probably the most exciting planet to observe through a telescope. While surface detail is subtle its rings are a unique site and you should be able to observe the Cassini division which appears as a black gap between the rings.

Mars also known as the Red planet will reveal a good amount of detail when close to Earth. Its orange colour is prominent and surface markings are visible as are the Polar caps when present.

Venus can be observed early in the morning before dawn or just after sunset. Venus appears quite large in the telescope but its atmosphere will hide any surface detail.

Deep sky observation greatly depends on the prevailing sky conditions. City lights, low sky transparency and the presence of the Moon will greatly affect what you can see through the telescope. From a dark site and under favourable conditions you will be able to see several deep sky objects including star-clusters, galaxies, nebulae and comets. Such objects with the exception of stars will appear as faint clouds of matter in monochrome, human eyes are not able to pick up colour. Cameras on the other hand can reveal colour and considerable amounts of detail.

Good deep sky objects to look for at the very beginning include the Orion Nebula, the Trifid nebula, the Ring nebula, the Andromeda Galaxy and a number of star-clusters among various other objects.

Observation Skills

In general it is easier to locate a target with a low power eyepiece i.e. 25mm. Once the target has been located centre it in the field of view before replacing the 25mm eyepiece with a high power one, i.e. 5mm (x240).

There are many factors that will affect the quality of the image through the eyepiece; such factors include sky quality in terms of the level of light pollution, sky transparency and the presence of the Moon if you are observing deep sky objects like galaxies and nebulae. If you use an equatorial mount make certain that the telescope has been balanced and that all screws are reasonably tight.

You will always be limited by the type, size and the optics of your telescope in what you can see. However there are other important factors to consider that can substantially improve the experience. Let the optics cool down for best results, this varies depending on the size and type of the telescope but typically a 127mm refractor like the ARC-127 QUAD will need around 15 minutes to cool down.

Please keep in mind that targets near the horizon will not look as sharp, targets near the zenith will look substantially sharper. Avoid setting your telescope on concrete; wood and grass are better as they do not release heat. Your line of sight should ideally not pass just over a warm house; the rising heat will substantially affect the quality of the image.

The long focal length of the ARC-127 QUAD scope makes it ideal for planetary and Lunar viewing. When conditions are not favourable the maximum useful magnification for most scopes will be around 25-35 times per inch of aperture. Otherwise expect higher practical magnifications per inch of aperture under favourable conditions with good quality eyepieces.

Dew shields are useful as they cut stray light entering the telescope, they also protect objective lenses from dew building up on the optics and also increase contrast. The ARC-127 QUAD comes with built-in dew-shield.

Observing the Sun

Special precautions need to be taken when observing the Sun with a telescope. A full aperture Solar filter must be used to dramatically reduce the amount of light that enters the telescope, only use filters designed to be used for Solar observation with a telescope. A second filter can also be used at the eyepiece end in conjunction with a full aperture Solar filter to increase the level of surface detail i.e. Solar Continuum Filters. Such filters work very well with digital cameras in particular and will reveal additional detail otherwise not visible to the human eye. Always check the integrity of any Solar filter before using it with a telescope. A hair-line scratch on a filter is enough to damage your eyesight. If in doubt seek professional advice and never point a telescope towards the Sun without a suitable Solar filter.

Visual Accessories

Depending on what came with your telescope you may need a number of extra eyepieces which will provide a wider range of magnifications. For example high magnifications are required for the Moon, planets and planetary nebulae. Low magnifications are useful for observing extended objects and for locating targets. Ninety degree star diagonals are necessary as they make astronomical observation comfortable. For terrestrial observation 45° degree prism diagonals are preferred, such diagonals will also offer a corrected view unlike star diagonals.

A 13% transparency Moon filter will be necessary to observe the Moon with almost all medium to large sized telescopes including the ARC-127 QUAD, light pollution filters can also help by reducing sky glow and incoming light from other local light sources. Finally a 2.5mm-3mm eyepiece is highly recommended for high power viewing of the Moon and planets.

These telescopes can perform well and as such they will benefit from quality optical accessories including the Opticstar XL range of premium tele-extenders, Zoom and prime eyepieces as well as the more affordable range of Opticstar XS eyepieces.

Imaging

The ARC-127 QUAD has been designed with imaging in mind. The telescope offers a good aperture, flat imaging field, fast focal ratio, reduced false colour at F5 and no obstruction. Most important the ARC-127 QUAD would be ideal for narrow band imaging when considering that false colour would no longer be an issue.

Being an air-spaced refractor with metal knife edge baffles the ARC-127 QUAD is also ideal for imaging and viewing the Sun when used with a specialist (H—alpha) Solar filter at the eyepiece end. Newtonian and catadioptric designs in general are not well suited for use with H-alpha eyepieces alone as the heat from the Sun will have an adverse effect on the smaller secondary mirror over time unless a specialist full aperture Solar filter is used. White light full aperture filters are ineffective as they also reduce the amount of H-alpha entering the telescope and reaching the H-alpha eyepiece.

Optics Care

Lenses can be treated as camera lenses for cleaning purposes. What makes them difficult to clean is the large size of such optical elements. The general rule is not to touch the optics and only clean them when absolutely necessary, dust on the objective lens could be removed with very gentle strokes of a camel hair brush or with an optics cleaning cloth available at camera shops.

You can remove condensation from the optics with a hair-dryer set to 'cold'. Otherwise bring the telescope inside and let condensation to dissipate before putting on the cover. Place the telescope on a table and not on the floor where most of the dust can be found. Never try to remove condensation using a cleaning cloth or similar, this will most likely smear the optics.

Optics Collimation

The telescope comes collimated from the factory. If there was a need the objective could be collimated by an experienced user, three sets of easily accessible screws allow for precise collimation. Collimation can take place on a star high up in the sky and under very good atmospheric conditions. Alternatively the telescope can be collimated or with the aid of an artificial star like the Opticstar Artificial Star XL

APPENDIX A

Appendix A outlines the most important aspects of a telescope in terms of its focal length and focal ratio. These values are important as they dictate magnification, exposure times when imaging and fields of view.

Practical Magnification

The focal length of a telescope can be calculated by multiplying the focal ratio of the telescope with its aperture i.e. an f5 refractor with 127mm of aperture will have a focal length of approximately 622mm ($4.9 \times 127 = 622$).

In a telescope, magnification is the number of times an object appears larger to the observer when compared to what the observer can see with the naked eye. There is no real limit to the amount of magnification possible in a telescope, but practical magnification is limited by the optical system and is normally around 30-40 times per inch, and around 50-70 times per inch of aperture for high quality apo-chromatic refractors. Experienced observers using high quality telescopes may push these figures even higher under favourable conditions.

Please keep in mind that the maximum useful magnification from a suburban yard using any telescope will be around x30 – x35 per inch of aperture for most of the time, this is due to light pollution (sodium lights in particular), thermal currents and other environmental factors. Expect higher magnification from dark sites and when transparency is good.

Eyepieces and Magnification

The actual magnification capability of a telescope will vary depending on the eyepiece attached to the telescope. Magnification can be changed by simply exchanging eyepieces.

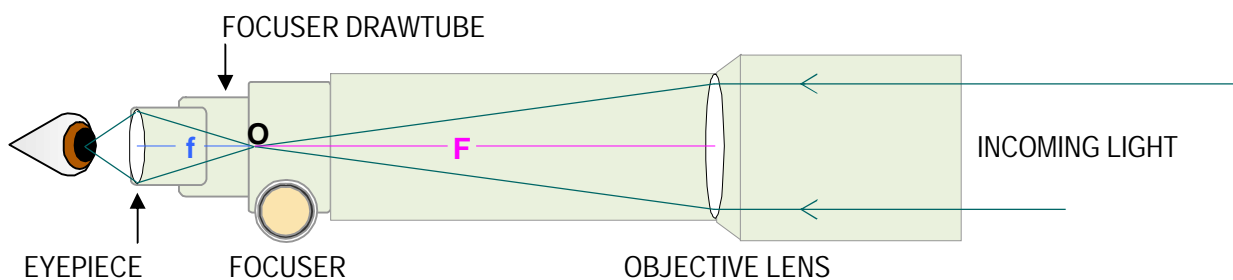

Magnification depends on two factors. The focal length of the telescope and the focal length of the eyepiece used. To calculate the magnifying power an eyepiece gives, simply divide the focal length of the eyepiece into the focal length of the telescope.

$$\text{Magnification} = \text{telescope's focal length} / \text{eyepiece's focal length} = F/f$$

For example a telescope with a focal length of 620mm and an eyepiece with a focal length of 10mm will magnify its target 62 times ($62/10=62$).

Barlow lenses can be employed in conjunction with an eyepiece to increase magnification. To calculate the magnifying power an eyepiece gives in conjunction with a Barlow lens, simply divide the focal length of the eyepiece into the focal length of the telescope and multiply the result by the Barlow's magnifying power.

$$\text{Magnification} = \text{telescope's focal length} / \text{eyepiece's focal length} \times \text{Barlow power}$$

For example a telescope with a focal length of 620mm used with an 10mm eyepiece and x2 Barlow will offer a magnification of x124 ($620/10 \times 2 = 124$).

Focal Ratio

The focal ratio represents the *speed* of the telescope's optics, the focal ratio can be calculated by dividing the focal length by the telescope's aperture.

Telescopes with faster/shorter focal ratios benefit from wider fields of view, and a subsequent increase in brightness and image resolution. Fast f/4-f5 focal ratios are generally best for lower power wide field observing and deep space imaging. On the other hand slow f/10 focal ratios and above are better suited to higher power Lunar and planetary observation as well as high magnification imaging in general.

For example when imaging extended deep sky objects like nebulae and galaxies an f/4 telescope will capture four times the amount of light in the same time period when compared to a telescope with an f/8 focal ratio. The same does not apply to single point light sources like stars where aperture alone dictates what you can see.

Field Of View

The field of view is the portion of the sky that is visible through the telescope and depends on the focal ratio of the telescope. In general higher magnifications result in smaller fields of view.

Short focal ratios (f/4) with wide fields of view greatly favour deep sky viewing and imaging, where focal ratios of f/10 and above are better suited for planetary and Lunar observation. Focal ratios in between these values (f6) may be considered appropriate for general use.

It is possible to calculate the field of view of a telescope given a certain eyepiece using the following formula.

$$\text{Actual Field of View} = \text{Eyepiece Apparent Field of View} / \text{Magnification}$$

$$\text{where Magnification} = \text{Telescope Focal Length} / \text{Eyepiece Focal Length}$$

Consider a telescope with a 620mm focal length and a 10mm eyepiece with a 50 degrees Apparent Field of View.

$$\text{Magnification} = 620 / 10 = 62 \sim \text{Actual Field of View} = 50 / 62 = 0.8 \text{ degrees}$$

APPENDIX B



Opticstar ARC-127 QUAD Specification	
Aperture	127mm
Focal ratio	F4.9
Focal length	622mm
Objective	4 achromatic lenses in two groups of 2, can be collimated
Optical coatings	Fully anti-reflection coated
Optical tube	Internally anti-reflection coated with metal knife-edge baffles
Dew shield	Yes
Finder-scope saddle	Yes
Focuser type	Rack & pinion with lock
Focuser	2" with 1..25" adapter (T-threaded for camera use)
Tube Rings	Dual rings with carrying handle and dovetail platform
Tube Weight	7.2Kg (inc. rings)
Tube length	970mm
Eyepieces	25mm Plossl
Star Diagonal	90° 1.25"
Finder scope	9x50 (with bracket)

WARNING!



DO NOT USE THE TELESCOPE TO LOOK AT THE SUN!

Opticstar Ltd
87 Washway Road, Sale
Greater Manchester
M33 7TQ
United Kingdom
WEB: www.opticstar.com - EMAIL: info@opticstar.com